

## INSTALLATION INSTRUCTIONS

DESCRIPTION: Rear Axle Slider Kit  
PART NUMBER: BN6-F21D0-V0, B3L-F21D0-V0  
MODEL: '17~ YZF-R6, '17~ YZF-R1



### **⚠ WARNING**

Please read and understand these instructions completely before installation to avoid possible injury, or damage to the accessory or vehicle.

### **NOTICE:**

Installation of this kit requires a torque wrench. This installation should be performed by an authorized Yamaha dealer or a qualified mechanic.

### **WARRANTY INFORMATION:**

In the United States, see your authorized Yamaha dealer for a copy of the Yamaha *Genuine Parts and Accessories Limited Warranty*

### **DEALER OR INSTALLER:**

These instructions contain important information for future reference and *must* be given to the customer.

## PARTS LIST:

No.	Part Number	Description	Qty
--	BN6-F21D0-V0, B3L-F21D0-V0	Rear Axle Slider Kit	--
①	*	Right Slider	1
②	*	Left Slider	1
③	*	Slider Bolt	2
④	*	Slider Rod	1

\* Part supplied with kit only and not available separately.

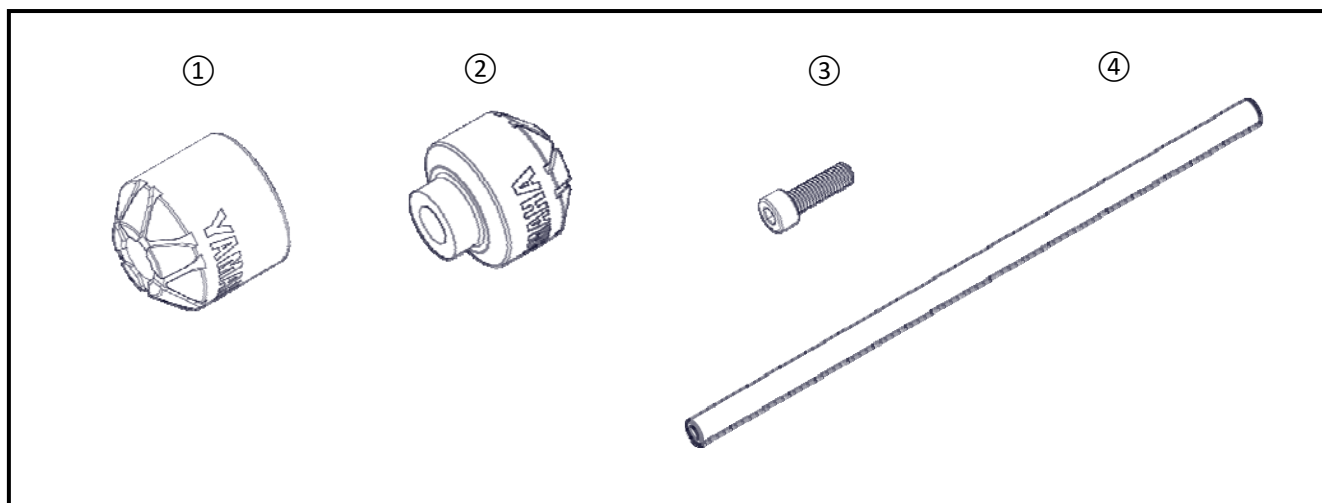

Fig. 1

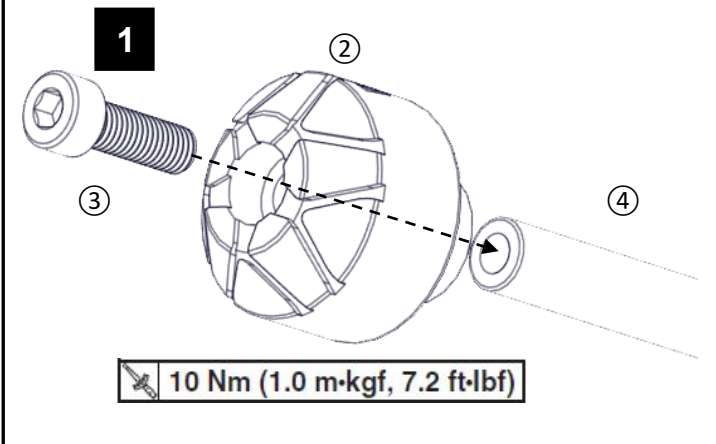
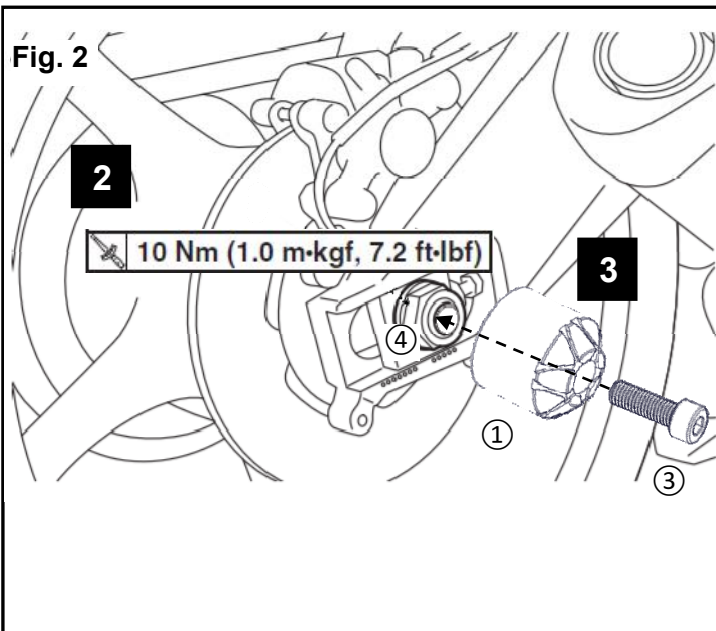

Fig. 2



**PREPARATION:**

- Stand motorcycle on a secure and level surface.
- Clean all mounting surfaces before beginning installation.

**INSTALLATION:**

- 1 Install the (3) Slider Bolt through the Left Slider (2) and thread into the (4) Slider Rod as shown in Fig. 1.
- 2 Install the assembled (4)+(3)+(2) slider into the center hole of the rear axle bolt. **Note:** You do not have to disassemble anything to install this kit.
- 3 Install the (1) Right Slider on to the (4) Slider Rod. Thread a (3) Slider Bolt through the center of the Right Slider and into the Slider Rod. Hold the Left Side (4)+(3)+(2) and Torque bolt to 10 Nm (1.0 m·kgf, 7.2 ft·lbf). See Fig. 2.

**MAINTENANCE:**

Periodically, check torque on all hardware. If loose hardware is found, re-torque to specification.

**CARE AND CLEANING:**

Clean sliders with a clean soft cloth and mild soap and water. Rinse and dry.

**CUSTOMER SERVICE:**

For further information see your Yamaha dealer.

**ESTIMATED TIME TO INSTALL: 0.1 HRS.**